



February 22, 2011

Dear Partners,

The Bill & Melinda Gates Foundation's U.S. Libraries program began with one goal: ensuring that if you can get to a public library, you can access the Internet to learn, explore opportunities, and enrich your life. More than ten years later, nearly every public library in the nation offers free use of computers and the Internet, and nearly one-third of Americans age 14 or older—approximately 77 million people—are using a public library computer or wireless network to access the Internet. The challenge now is to continue to expand Internet and technology services to meet the growing needs of patrons.

As part of our effort to support libraries in sustaining and improving public computer and Internet access for communities, we have funded studies to learn more about the ways libraries can connect to and maintain high-quality Internet service. Last year, we funded the American Library Association Office of Internet Technology Policy's (OITP) to develop the report, ["Making Connections: Lessons from Five Shared Library Networks."](#) That publication provides practical information and case studies that outline various public library connectivity options.

**Today, we are pleased to share with you the findings of a new study we commissioned to explore the potential benefits of research and education Internet networks for public libraries.** The attached findings developed by the telecommunications strategy firm CSMG, are intended to illuminate the unique attributes of research and education networks, and to consider how libraries can utilize those assets to support improved connectivity and new applications for patrons.

The foundation commissioned this study in response to the National Telecommunications and Information Administration's unprecedented investments in state and regional fiber networks through the Broadband Technology Opportunities Program (BTOP). The expansion of broadband through research and education networks creates new opportunities for public libraries to connect to the Internet and access a variety of "value-added" services.

Our thanks to many of our colleagues in the public library and R&E network fields who provided extensive consultation to inform this report. We hope this resource will be valuable to public libraries in assessing their options to secure broadband access and continuing to provide high quality technology access to the communities and patrons they serve.

Best,

Jill Nishi  
Deputy Director, U.S. Libraries and Special Initiatives  
Bill & Melinda Gates Foundation

# Connections, Capacity, Community:

Exploring Potential Benefits of Research and Education Networks for Public Libraries

A study commissioned by the Bill & Melinda Gates Foundation

February 21, 2011

---

---

# Table of Contents

---

Introduction and Summary.....	1
Methodology.....	1
The Origin and Evolution of Research & Education Networks .....	3
The Value Proposition of Research & Education Networks .....	6
1) Basic Value .....	6
2) Added Value .....	11
Requirements for R&E Network Service to Libraries .....	16
R&E Networks Are Well Positioned to Serve Libraries .....	19
Appendix: Dimensions of R&E Networks .....	20
Scope of Membership .....	21
Service Depth.....	21
Geographic Reach .....	21
Origin.....	22
Governance.....	23
Business Model.....	23
Network Topology .....	23

---

---

# Introduction and Summary

---

The purpose of this paper is to highlight ways in which “state research and education networks” (R&E networks) and community anchor institutions, particularly public libraries, can collaborate to provide high-quality broadband connections for users in the communities they serve. Originally developed to connect campus research centers with high capacity internet and computing services, Research and Education networks have expanded over time, offering non-commercial services to K-12 education, libraries and other community institutions. Fortified with additional funding from Federal stimulus investments, these networks and other nonprofit networks are poised to reach more buildings and serve more users. This study considers the value of, and impediments to, expanding R&E network service to libraries.

State R&E networks have grown organically over the last two decades. These networks have a variety of missions, governance structures, service strategies, business models, and network architectures. In many instances, R&E networks can provide high-speed, high-quality connectivity to public libraries at a low cost with value-added services such as such as videoconferencing, digitized content, library-generated content and learning management systems. These nonprofit networks often operate with a membership model creating opportunities for member institutions to share best practices, content, and programs and to collaborate on network planning.

State R&E networks are like the state highways of the Internet, providing high capacity routes or “middle mile” connections to major locations within a state, relying on national networks for long-distance connections and local “last mile” connections to reach smaller communities and buildings within a community. Increased middle mile funding provided by federal stimulus funds, through the Broadband Technology Opportunities Program<sup>1</sup> promises to accelerate expansion of R&E networks, bringing high capacity internet connections to more communities across America. As a result, in the coming months, thousands of additional community anchor institutions, including public libraries, will have new opportunities to benefit from increased bandwidth and additional value-added services through R&E networks. R&E networks have an important role in helping to achieve the goal in the National Broadband Plan that “Every American community should have affordable access to at least 1 gigabit per second broadband service to anchor institutions such as schools, hospitals and government buildings.”

This paper outlines the potential benefits and challenges for libraries and other community anchor institutions considering connecting to an R&E network.

## METHODOLOGY

This research project was executed by CSMG, a Boston-based telecommunications strategy consulting firm. The study leverages CSMG’s deep networking industry experience, extensive secondary research, along with findings from in-depth interviews with many library and network leaders. Over the course of several weeks, CSMG interviewed 43 individuals from 28 unique organizations including 19 state research education network leaders and 24 leaders of state and local libraries. The findings were validated through repeated reviews with a select group of network leaders. The U.S. Libraries Program at the Bill & Melinda Gates Foundation collaborated with CSMG on the discussion of findings presented in this report.

The Bill & Melinda Gates Foundation and CSMG would like to acknowledge the important contributions of the members of the advisory group of network leaders including: Gary Bachula, Robert Bocher, Jim Dolgonas, Joe Freddoso, Jen Leasure, George Loftus, David Reese, Marijke Visser, Donald Welch, James Werle and John Windhausen.

---

<sup>1</sup> See Sec. 6001 Broadband Technology Opportunities Program in *American Recovery and Reinvestment Act of 2009* at 398, available at [frwebgate.access.gpo.gov/cgi-bin/getdoc.cgi?dbname=111\\_cong\\_bills&docid=f:h1enr.pdf](http://frwebgate.access.gpo.gov/cgi-bin/getdoc.cgi?dbname=111_cong_bills&docid=f:h1enr.pdf)

## Glossary of Key Terms

**Busy Hour:** The hour during which the maximum traffic load occurs in a given 24 hour period

**Cloud Computing /Services:** location-independent computing, whereby shared servers provide resources, software, and data to computers and other devices on demand. Cloud computing is a natural evolution of the widespread adoption of virtualization, service-oriented architecture and utility computing

**Commercial Service Provider (CSP):** An organization that provides service (e.g., telecommunications, Internet, IT or consulting services) in return for payments intended to produce a profit

**Commodity or Commercial Internet:** the part of the Internet operated by commercial service providers

**Community Anchor Institution (CAI):** institutions that contribute to communities' education, health, or public safety; examples given by the NTIA include schools, public libraries, community colleges, hospitals, clinics, and public safety facilities

**Contention (ratio):** Ratio of potential maximum bandwidth to actual bandwidth; a higher ratio indicates that more users are utilizing a designated amount of bandwidth, thereby reducing the effective bandwidth offered (see also oversubscription ratio)

**Cross-Subsidization:** The practice of using higher rates or greater revenue generated by one customer to subsidize service to another customer

**Intranet:** A network that can be used by connectors to transfer data between each other without travelling over another network; R&E networks function as Intranets within many states

**Last Mile (also tail or lateral circuit):** The segment of the network that is the final leg over which broadband connectivity is delivered; it connects the endpoint location (e.g. library) to the nearest network service provider point of presence (e.g., existing fiber splice point, network hub, or central office)

**Member:** denotes a user of, or connector to, an R&E network Members often participate in network governance, user forums, and self-organize to share content, etc.

**Middle Mile:** The segment of the network that links a network operator's core network (backbone) to the local network plant (or last mile). This differs from NTIA use of the term that sometimes includes (last mile) connections to anchor institutions

**Network Effect:** The effect that one user of a good or service has on the value of that product to other people. When network effect is present, the value of an internet-based application or service increases as more people use it

**Oversubscription Ratio:** (see also contention ratio) it is calculated by adding the potential bandwidth requirements of a particular path and dividing the total by the actual bandwidth of the path

**Postalization:** The establishment of a uniform pricing structure (for example by dividing total costs by the number of R&E network members); this practice helps enable more geographically remote R&E network members to cost-effectively connect

**Regional R&E Network:** A physical network and related non-profit organization dedicated research and education applications that spans multiple states and connects state R&E networks and institutions across states (Note: regional networks sometimes refer to localized networks in a sub-region within a state, but for the purposes of this paper a regional network is one that covers multiple states)

**State R&E Network:** A physical network and related non-profit organization dedicated to research and education applications that exists mostly within a single state and seeks to connect institutions across as much of the state as possible

---

# The Origin and Evolution of Research & Education Networks

---

While a handful of research and education networks trace their roots to the 1960s, contemporary R&E networks began to form in the mid-1980s. In 1984, the National Science Foundation (NSF) launched a supercomputing program to provide researchers from around the country with access to high performance computers. As part of this program, the high-speed network, NSFNET, was created to connect research and academic networks.<sup>2</sup>

Once NSFNET was launched in 1986, there was a flurry of activity in state legislatures and in the higher education community to get colleges and universities connected to the Internet and to each other. In 1985, NYSERNet was established by a consortium of New York universities and corporations to create a statewide network that would connect members to each other, to the supercomputing centers at Cornell and Princeton, and to the NSFNET.<sup>3</sup> Two years later, the Ohio Board of Regents followed suit with the creation of OARNet. Similar initiatives were seen in a number of other states through the early and mid-1990s.

As the Internet took hold in the mid-1990s, state and federal governing bodies recognized the Internet as a useful tool for the broader educational community. This awareness, along with funding efforts at the state and federal levels, helped existing R&E networks in some states to expand service to K-12 schools and community colleges.

Since the advent of the Internet and initial NSF funding in the 90s, R&E networks have gradually evolved and expanded. This expansion – from founding universities to community colleges and K-12 – R&E networks has remained primarily focused on the K-20 community. Recent events, however, will result in a second wave of rapid expansion.

In 2010, \$3.5 billion was awarded to state agencies, commercial entities, non-profits, and R&E networks as part of the Broadband Technology Opportunities Program (BTOP) Comprehensive Community Infrastructure (CCI) program.<sup>4</sup> One of the defined purposes of the CCI program was to expand middle mile fiber capacity and “connect ‘community anchor institutions’ such as schools, libraries, hospitals, and public safety facilities.”<sup>5</sup> The program accelerates the deployment of broadband capacity by enabling award recipients to build out networks in areas that previously had a shortage of fiber. Of the 111 CCI projects focused on broadband,<sup>6</sup> 61 commit to serve a total of 2,381 public libraries. The remaining 50 may also connect libraries, but do not disaggregate a number of libraries from the number of planned connections to community anchor institutions.

Just as state highways connect communities across a state to each other and to the inter-state highway system, middle mile fiber projects stand to expand high capacity Internet connections for community anchor institutions across America. These build-outs will at least indirectly facilitate high-speed library Internet connections by decreasing libraries’ distance

---

<sup>2</sup> The Launch of NSFNET, *available at* <http://www.nsf.gov/about/history/nsf0050/internet/launch.htm>

<sup>3</sup> See “1985-Beginnings” in History of NYSERNet, *available at* <http://www.nysernet.org/history.php>

<sup>4</sup> The American Recovery and Reinvestment Act of 2009, the economic stimulus package designed for recession recovery, allocated a total of \$4.7 billion to the National Telecommunications and Information Administration (NTIA) for the purposes of investing in and encouraging the deployment and usage of broadband infrastructure and public computer centers. The NTIA administers these efforts through the Broadband Technology Opportunities Program (BTOP), which includes three initiatives: comprehensive community infrastructure (CCI), public computer centers (PCC), and sustainable broadband adoption.

<sup>5</sup> See Sec. 6001 Broadband Technology Opportunities Program in *American Recovery and Reinvestment Act of 2009* at 398, *available at* [http://www.firwebgate.access.gpo.gov/cgi-bin/getdoc.cgi?dbname=111\\_cong\\_bills&docid=f:h1enr.pdf](http://www.firwebgate.access.gpo.gov/cgi-bin/getdoc.cgi?dbname=111_cong_bills&docid=f:h1enr.pdf)

<sup>6</sup> Excludes projects in Puerto Rico, Guam, and the U.S. Virgin Islands and projects related to public safety mobile broadband networks.

from fiber (and therefore the cost to build lateral circuits) and by increasing the amount of bandwidth available in remote areas (regardless of whether libraries ultimately connect via commercial service provider or via R&E network). There are 38 active state R&E networks in the U.S. today, of which 22 serve libraries (see *Exhibit 1* below). BTOP infrastructure projects will lead directly to the connection of at least seven percent of all public libraries in the U.S. by facilitating the launch of three new R&E networks<sup>7</sup> and by expanding seven R&E networks' coverage of libraries.<sup>8</sup> We estimate that close to one-third of the United States' approximately 17,000 public libraries will be served by advanced fiber networks upon completion of announced BTOP projects. However, even if all these plans are fully executed, a significant amount of work remains in order to effectively connect all public libraries to high-speed, high-quality Internet.

The current network expansion creates an opportunity for public libraries and other anchor institutions to consider R&E networks as a source of affordable high-speed broadband and related value-added services. This paper presents seven dimensions to consider when working with an R&E network partner: the scope of the network's membership base, range of services, geographic reach, history and origin, governance, business model, and network typology. R&E networks often employ a membership model, where participants actively collaborate in network and service decisions. Understanding the nature of the R&N network and its organization will help libraries determine whether a particular R&E network is a good fit for their network and service needs.

The first dimensions that libraries may wish to consider are the two that impact them most directly:

- *Scope of Membership*<sup>9</sup> and *Service Depth*. These two factors will largely determine whether, and to what extent, a library can benefit from its state R&E network.

The other five dimensions are important as well:

- *Governance* drives the extent to which a library may influence an R&E network's management.
- *Origin* impacts R&E networks' capabilities and focus.
- *Network Topology* impacts whether a library may be connected directly to R&E network fiber or through a leased circuit from a commercial provider.
- *Business Models* influence the cost to join an R&E network as well as an R&E network's financial stability.
- *Geographic Reach* is an indicator of the breadth of R&E network coverage. Middle mile networks operate within a state or multi-state region. National networks span the country and usually have international gateway connections. For reference we have included a table at the end of the appendix that lists the thirty-eight active state R&E networks and which types of anchor institutions they appear to serve today. This is a dynamic environment, so libraries looking for broadband services would be well-served to speak with their state R&E network to confirm its scope and breadth of service.

---

<sup>7</sup> R&E networks launching with BTOP funding include: New Hampshire, Pennsylvania (KINBER/PennREN), and West Virginia. These R&E networks will serve 234, TBD, and 176 respectively. New Hampshire: see State Review of NTIA Applications, submitted April 30, 2010, available at [www2.ntia.doc.gov/files/BTOP\\_Recommendation\\_NH.pdf](http://www2.ntia.doc.gov/files/BTOP_Recommendation_NH.pdf). West Virginia: see West Virginia Statewide Broadband Infrastructure Project Factsheet available at [www2.ntia.doc.gov/files/grantees/WV\\_ExecOfcWestVA\\_FINAL.pdf](http://www2.ntia.doc.gov/files/grantees/WV_ExecOfcWestVA_FINAL.pdf)

<sup>8</sup> The six R&E networks expanding their coverage to libraries are 1) EAGLE-Net of Colorado will expand its mission with plans to connect 26 libraries, 2) MCNC/NCREN – plans to connect 235 libraries, 3) WiscNet – plans to connect 385 libraries, 4) Utah Education Network – plans to connect 35 libraries, 5) Iowa Communications Network – plans to connect 50 libraries, 6) Merit – plans to connect 4 libraries, and 7) Hawaii Education and Research Network – plans to connect 50 libraries. Note that fifty other CCI projects plan to connect anchor institutions but did not specifically designate libraries as beneficiaries.

<sup>9</sup> R&E networks often use the term “member” to refer to entities that connect to them. This term reflects the fact that these networks offer a different model than a typical service provider that provides “customers” with a certain speed for a certain price. R&E networks offer their members a range of community driven benefits that we will explore in detail in the value proposition section. Members often participate in network governance, user forums, self-organize to share content, etc. Many anchor institutions find these opportunities to engage valuable but they are under no obligation and may instead choose to simply connect and pay for service. In this paper, we use the term “member” to refer to a user of, or connector to, an R&E network.



---

# The Value Proposition of Research & Education Networks

---

In many instances, R&E networks provide high-speed, high-quality connectivity, value-added services, and a forum for collaboration. Because public libraries, and many other community anchor institutions, are cash-constrained, cost is often the primary concern when they choose a broadband provider.<sup>11</sup> However, comparing offers based on advertised bandwidth alone may not reflect the actual value of a network service. There are many facets of R&E network services that differentiate them from basic broadband service and that can be advantageous for community anchor institution.

R&E network value can be considered in two core areas: *basic value* (network speed, quality, and cost) and *added value* (value-added services, community of users).

## Exhibit 2: The Key Elements of the R&E Network Value Proposition

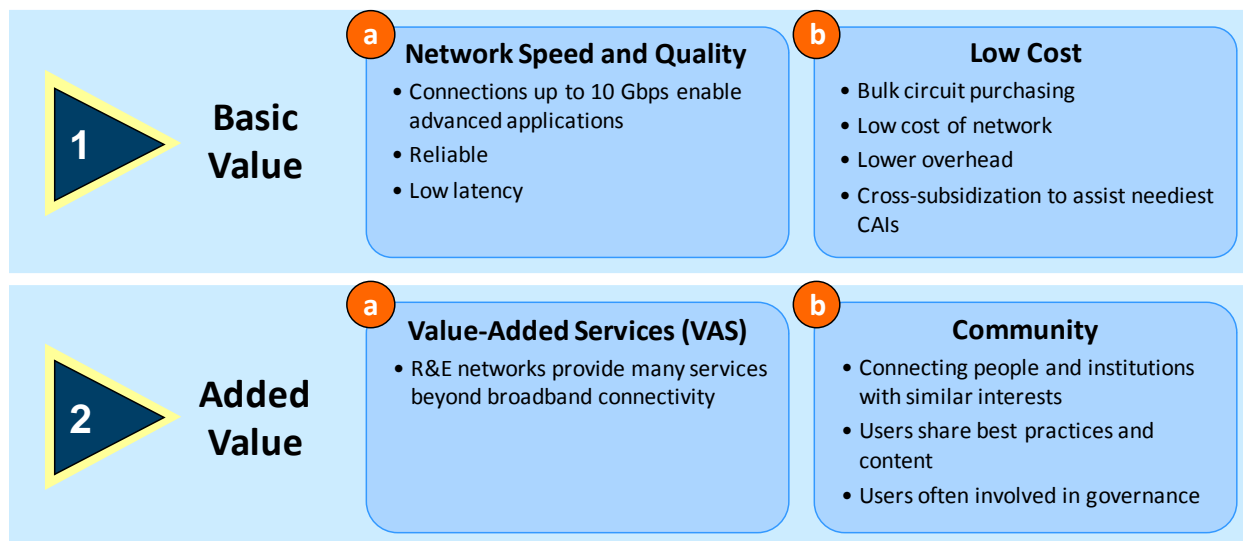

### 1) BASIC VALUE

When choosing broadband service, libraries must often prioritize price over speed and other factors. However, as illustrated in *Exhibit 3* below, new library services and end-user applications demand greater interactivity and higher bandwidth. As a result, libraries will need to consider not only speed and price, but also other performance measures such as latency, contention and burstability. Sections 1a and 1b below define these requirements in more detail and lay out characteristics and practices of R&E networks that enable them to deliver premium connectivity at favorable prices.<sup>12</sup>

---

<sup>11</sup>This is also driven by the fact that the E-rate program requires cost to be the primary factor in selecting a provider.

<sup>12</sup> Premium connectivity benefits (such as less latency, reduced contention and burstability) accrue when an anchor institution is connected directly to an R&E network on a circuit that it controls – ideally R&E network owned and operated fiber.

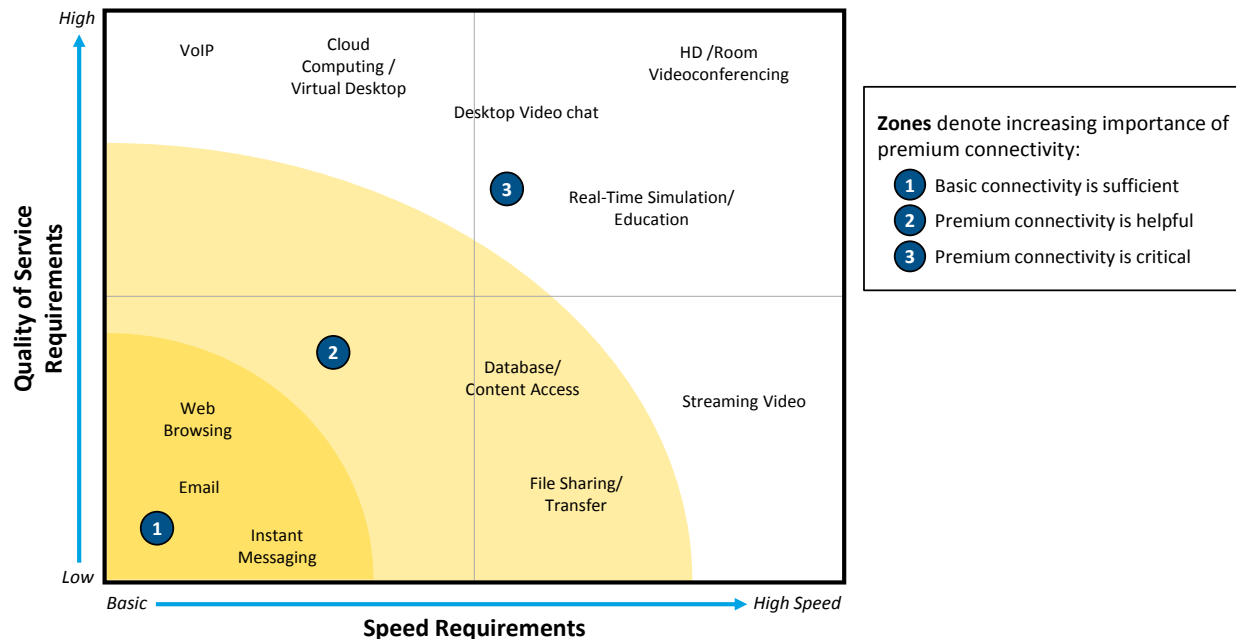
**Exhibit 3: Quality of Service and Speed Requirements of Example Applications**

### 1a) Network Speed and Quality

Increasingly, library patrons use technologies and applications that require high-quality Internet bandwidth, such as high definition videoconferencing, desktop video chat (e.g. Skype), online learning and assessment, streaming video, and Voice over Internet Protocol (VoIP). As shown in *Exhibit 3*, many of these applications require some combination of high bandwidth (speed) and high Quality of Service (QoS). Quality of Service parameters include measures of latency (transmission delay) and jitter (variability in the timing of packets' arrival.) Another consideration for many emerging applications is the need for symmetrical bandwidth, which refers to the ability to transmit (upload) and receive (download) data at the same rate.

R&E networks have been designed to meet the needs of some of the most demanding Internet users in the country: scientists, academics and researchers in our nation's leading academic institutions. The networks are engineered to support these demanding users with high quality services that are consistent regardless of the number of users on the network and that flexibly adapt to new experiments or projects that place new demands on the network. In other words, networks as designed to provide "frictionless support" for the work of research and education, ensuring that the network itself is never a constraint to the work at hand. Libraries that connect to R&E networks may be the unintended beneficiaries of this design principle. The network speed, quality and flexibility offered by R&E networks can provide libraries a high level of service, and one that adapts easily to user demands.

To ensure their ability to support the most demanding research applications, R&E networks have engineered and built low latency, un-contended networks that they operate un-throttled (allowing bursting and without capping customers' throughput). Each of these important quality requirements is discussed below.

#### **Low Latency**

Latency is the amount of time required for a data packet to get from point A to point B (usually measured in terms of round-trip delay or "ping rate" in milliseconds). Low latency is especially critical for real-time applications, such as videoconferencing and cloud computing. As users in schools and libraries more actively participate in distance learning, remote job interviews, and remote training over high-definition videoconferencing, latency will become increasingly important. A high latency connection, one which delays or drops packets will make real-time communications look and sound jittery, distorted, or garbled. Voice and video communications become choppy and unsynchronized. Video frame rates may drop.

R&E network architectures are optimized and provisioned with more than adequate capacity (referred to as headroom) to minimize latency. Most R&E network traffic stays within the network which has been architected to minimize “hops.”<sup>13</sup> This more direct routing eliminates delays caused by congestion of excessive “hops” in the public Internet. For example, traffic traversing Colorado’s EAGLE-Net makes an average of only 3-4 hops to reach its endpoint. Similarly, according to John Gillispie of Missouri’s MOREnet, traffic on his network takes about 10 milliseconds to reach an Internet gateway which easily meets the requirements of demanding real-time services such as VoIP, videoconferencing, and cloud services.

R&E networks are typically built and maintained to such standards that traditional approaches to ensuring service quality are unnecessary (i.e., they do not require the use of Quality of Service protocols to prioritize real-time traffic over less time sensitive traffic). When a user’s data travels within a given R&E network, or traverses from one R&E network to another, the packets consistently arrive without noticeable delays because the networks are uncongested (have headroom) and direct routes are available that do not introduce delays due to extra hops.

### Low Contention

Contention refers to conflicts over resources in a shared network. Contention happens when more than one user’s data packets are trying to use the same network capacity. It can occur at any point within a network where there is the potential for more traffic to be aggregated than the network’s capacity at that point. Since not everyone uses network resources at the same time and in the same way, most networks plan for some level of contention, or oversubscription of the aggregate network capacity. In a contended network during the busiest hour(s), the network’s capacity may be “oversubscribed” at a 20:1 or 40:1 contention ratio.<sup>14</sup> A network with low contention rates may plan for busy hour subscription at a rate or 1:1 (un-contended) or 2:1 (low contention).

**Exhibit 4: Differences in Internet Throughput During Busy Hour, By Network Type**

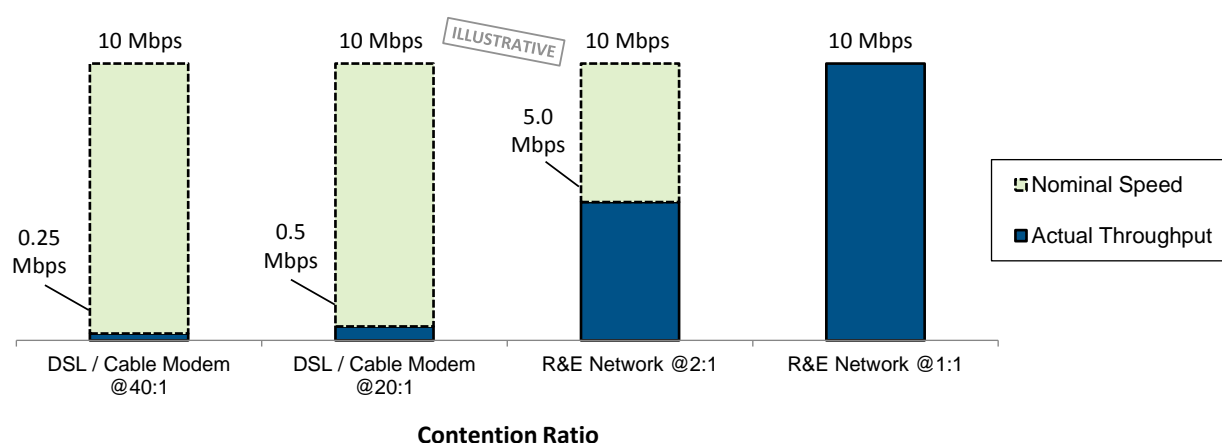

As illustrated in *Exhibit 4*, in a 20:1 contended network when multiple subscribers connect to the Internet through a common network element and attempt to use their full advertised “nominal” speed, they may each end up getting as little as one twentieth (5%) of the advertised speed to which they subscribed. A network is made up of a series of shared network elements or segments. However, from a customer’s perspective, network performance or capacity is only as strong as the weakest link in the network chain, typically the last mile or middle mile connection. If these segments are highly contended, the user will experience much less throughput than the maximum or advertised speed.

<sup>13</sup> The number of hops is the number of connection points between networks that must be made for a data packet to reach its final destination.

<sup>14</sup> This ratio of total nominal/advertised throughput to total capacity is also known as the *oversubscription ratio*.

In fact, an oversubscription ratio of 20:1 is a standard engineering guideline for cable modem (Hybrid Fiber Coax/DOCSIS) and DSL-based networks.<sup>15</sup> Internet backbone traffic also tends to be highly aggregated. Oversubscribing enables service providers to provide service to large numbers of subscribers at affordable rates. R&E networks, as illustrated in *Exhibit 4*, typically limit over-subscription yielding an effective throughput equal to, or very near, the nominal speed purchased.

Differing contention ratios of various types of connections are important for libraries to consider when comparing service offerings. Depending on the technology and network architecture, subscribers may need to purchase significantly larger connections to consistently achieve a desired level of performance. Information Technology (IT) buyers at libraries should seek detailed information from potential service providers about the type of connection and its contention ratio. Business services from commercial service providers such as Ethernet and MPLS<sup>16</sup> tend to be less congested than consumer services such as DSL and cable modems. For some premium over a basic connection, it may also be possible to purchase a dedicated circuit with a committed information rate.

Public libraries and other community anchor institution may not be fully aware of differences in effective busy-hour throughput when they are selecting a service provider but the decreased busy-hour performance will impact their users' experience considerably. A simple and effective way for libraries to gauge the actual throughput (and latency) of their existing connection is by using a free test site at various times of the day and week.<sup>17</sup> If library computer users notice a decrease in performance at different times of the day, such as right after school lets out, this may be indicative that actual network performance is being reduced by over-subscription in a contended network.

### ***Burstable Network Capacity***

R&E networks are designed to handle research applications that can drive sudden spikes in Internet traffic. R&E networks typically do not cap or throttle subscribers' throughput. They instead allow subscribers to transmit and receive "bursts" of data above the nominal speed to which the organization has subscribed. For example, if an organization subscribes to 10Mbps connection but occasionally uses 20Mbps or 30Mbps, R&E networks typically accommodate these bursts of demand without charging more. Some R&E networks have actually moved away from charging based on usage or throughput so as not to discourage usage of advanced applications.<sup>18</sup>

R&E networks generally engineer and operate their networks to maintain ample headroom and offer practically unlimited capacity. From an end user's perspective, the headroom to accommodate "bursty" applications increases the quality of service because it prevents spikes in demand from causing delays and other service issues that result when networks approach their capacity. Additionally, community anchor institutions with occasional need for greater throughput are accommodated without having to pay for a higher speed connection.

### **1b) Low Cost**

An important benefit an R&E network provides to members is low costs/pricing. An R&E network's ability to hold down costs for members is a function of three main things: 1) its role as demand aggregator, 2) low network costs and cross-subsidization, and 3) its non-profit status and mission. *Exhibit 5* illustrates how R&E networks drive costs down at each network segment.

<sup>15</sup> Haran, Onn, and Sheffer, Amir. "The Importance of Dynamic Bandwidth Allocation in GPON Networks." *PMC-Sierra*. Jan. 2008: 12

<sup>16</sup> MPLS refers to Multiprotocol Label Switching, a networking approach used to efficiently deliver data across large IP networks.

<sup>17</sup> <http://www.speedtest.net/>

<sup>18</sup> Although it should be noted that flat rate pricing may have the un-intended consequence of pushing some R&E networks' entry-level pricing above the reach of smaller community anchors.

## Exhibit 5: Ways R&E Networks Lower Costs for Community Anchor Institution Users at Each Segment of the Network

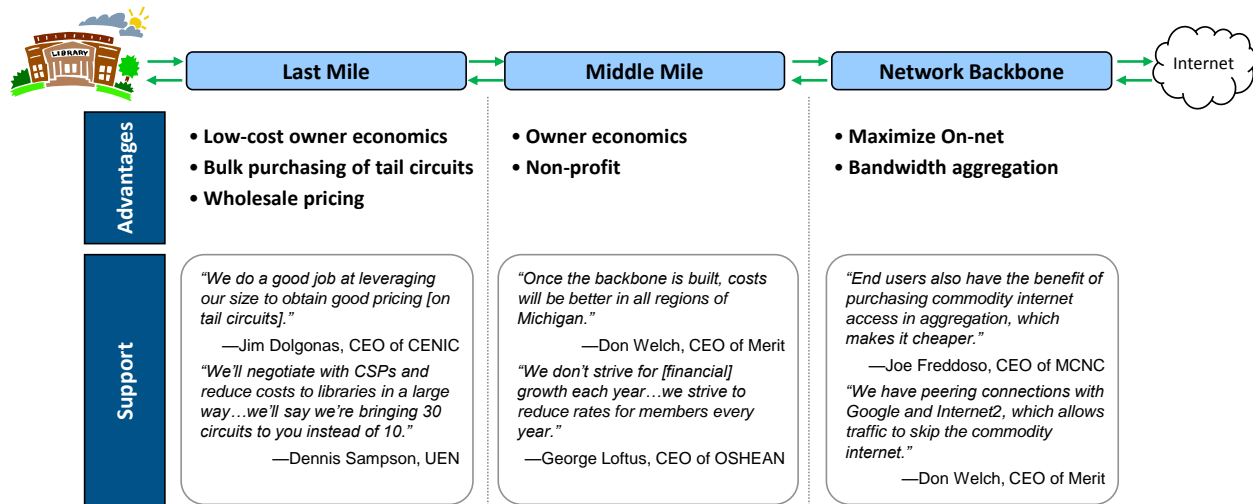

In the network backbone, where traffic is consolidated for long distance travel, R&E networks pay per-megabit transit charges for traffic that connects to the commercial Internet. Since R&E networks purchase backbone access "in bulk," they are able to get excellent pricing in this highly competitive segment of the network services market. In the middle mile, R&E networks drive greater cost savings by keeping as much data as possible on their owned regional fiber networks, offering very low marginal cost per bit. The greatest potential cost savings is often associated with "last mile" connections, the "tail circuits" that connect a specific building to the network. Connecting a building directly into the R&E network with owned fiber effects the greatest savings but R&E networks can also provide significant savings to anchors through bulk purchasing of tail circuits.

### Demand Aggregation

Typically, an R&E network only owns and operates a portion of the actual service network. Additional circuits are purchased directly from other service providers. When purchasing network services, demand aggregation is a key lever by which R&E networks provide value to their members. For example, MCNC<sup>19</sup> of North Carolina has hundreds of connecting participants. By pooling all of these entities, MCNC creates what looks like a very large enterprise to a commercial service provider. MCNC can then leverage its purchasing power to negotiate rates that are more favorable than those that an individual entity could procure for itself. Moreover, by working with commercial service providers (CSPs) on a regular basis MCNC has accumulated the knowledge and relationships necessary to work out cheaper, more flexible deals with commercial providers.

In most states, R&E providers operate middle mile networks, but may not have last mile circuits to connect members. R&E networks typically require that libraries and other community anchor institutions pay for their last mile circuit. When the R&E provider aggregates the needs of a number of libraries or community anchor institutions to purchase (for example) 30 tail circuits, they are often able to procure those services at attractive prices. This is due to a number of factors:

- By acting as a single point of aggregation, the R&E network reduces the CSP's customer-facing costs, such as sales & marketing, billing, network support, and customer care, enabling the CSP to profitably sell the R&E network circuits with lower wholesale pricing.
- As networking industry veterans, R&E networks have tremendous depth of knowledge and longstanding relationships with a variety of CSPs that allow them to negotiate much more effectively (by bringing in additional competitors and by asking the right questions).
- By purchasing the circuits in bulk it increases its negotiating power and gets a quantity discount

<sup>19</sup> The operator of North Carolina's NCREN, <https://www.mcnc.org/about.html>

- R&E networks aggregate traffic going out to the commodity Internet and are able to negotiate better pricing with Internet service providers (ISPs) through a competitive bidding process. In fact, R&E networks are particularly desirable customers for ISPs that specialize in commodity Internet service because they often aggregate a large number of entities and “eyeballs” that enable the ISPs to peer with Tier 1 service providers on more equal footing and therefore at a lower cost.<sup>20</sup>

### ***Lower Network Costs and Cross-Subsidization***

Practically speaking, capital costs are approximately the same for similar types of networks; however the non-profit business model affords R&E networks pricing options that might not be available to commercial providers. R&E networks generally have no marketing expense, limited administrative costs, and sometimes operational expenses are reduced by employing students to provide a portion of the network support.

The BTOP Comprehensive Community Infrastructure Grants lower the capital costs for grant recipients and for providers who purchase wholesale services from those providers, thereby lowering network costs and capital recovery requirements for many potential customers. When an R&E network has built middle mile infrastructure into the vicinity of – or potentially directly to – a community anchor institution, service can be provided without having to incorporate the full capital expenditure cost recovery into the service charge. Leaders of libraries and other community anchor institutions should look for such opportunities because once the last mile is in place, R&E networks are often able to offer service at very attractive monthly rates. Whether the R&E network manages the last mile build or the anchor institution does, the institution is only charged for the incremental cost. In some cases it will be worthwhile for a community anchor institution to finance its own last mile connection to an R&E network in order to gain access to direct service with a lower monthly cost of service that justifies the cost of the build-out. E-rate funds can also be used to help support the cost of bringing fiber to libraries and K-12 schools. An FCC E-rate Order, released in September 2011, also allows any entity to provide fiber, not just a common carrier. This enables E-rate support for R&E networks provisioning fiber to libraries.

Some R&E networks also employ forms of cross-subsidization among their members. An R&E network may charge a postalized or uniform price to all members for connectivity regardless of the cost to connect a given member. Under postalization, connectors who are closer to the middle mile network that are easier and cheaper to reach with a fiber lateral may pay more than their actual costs, which subsidizes connections for more remote members. Another common form of cross-subsidization that R&E networks apply is to charge larger members enough to generate a small surplus that helps the R&E network to affordably service smaller institutions. However, in either form of cross-subsidization, the closer or larger subsidizing entities ultimately benefit as new members pick up a share of other fixed costs and help drive economies of scale. Conversely, postalization can be disadvantageous to libraries if the flat rate charged includes services that the library does not need.

### ***Nonprofit Mission***

Finally, because R&E networks are non-profit, cost savings or operating surpluses are used to reduce user costs or make network upgrades. One R&E network reported that it has reduced rates by 3-5% every year and proactively upgraded a library system from 10Mbps to 30Mbps at no cost. Other R&E networks charge for higher margin services such as cloud services, network consulting, or hosting to bring in extra revenue to help keep connectivity prices low instead of maintaining a profit margin.<sup>21</sup>

## **2) ADDED VALUE**

State librarians report that cost was the number one issue they focused on when purchasing broadband connectivity for the library. R&E network services, at any given location, may or may not be competitive based on cost and service quality. However, some institutional purchasers, including libraries, are finding that the suite of value-added services offered by R&E networks merit a closer look. For example, when one state librarian was presented with the full range of

<sup>20</sup> Peering occurs when two networks exchange traffic between each other's customers freely, and for mutual benefit. Smaller, non-Tier 1, networks are typically required to pay “transit charges” to connect with Tier 1 networks.

<sup>21</sup> Conversely, it should be noted, that many R&E networks, rather than taking an “a la carte” approach, charge a fixed cost for basic membership that covers services that a typical library does not need. Depending on the structure of the membership fee this can result in membership pricing that less attractive to libraries.

value-added services (VAS) some R&E networks offer, he pointed out that the potential cost savings and value derived from the bundle of VAS could offset the higher cost of connectivity (in the case where an R&E network's broadband pricing appeared higher than that of a commercial alternative).<sup>22</sup>

When individual libraries or library systems consider commercial and nonprofit broadband connections, they should look closely at the suite of value-added services offered by each provider and consider the relevance of each offering to their institutional needs. As library systems expand their use of broadband as a transformational element in their business and service plans, and build from trials and initial pilots, R&E networks can be great partners in bringing broader “value added” services to scale across the library field and in partnership with other community anchor partners.

We anticipate that R&E networks' value to libraries will grow and broaden as libraries' capabilities, needs, and practices evolve. Broadband-enabled services are evolving from narrowly focused “point solutions” to broader integrated solutions with the potential, ultimately, to transform the way libraries operate. Libraries are leveraging R&E network-based communities to explore a wide range of transformational ideas such as centralizing library management services using hosted open source solutions, better integrating libraries as outlets for e-government, enhancing and coordinating libraries' role in primary and continuing education.

## 2a) Value-Added Services (VAS)

As noted above, and illustrated in *Exhibit 3*, high-performance R&E networks enable a range of advanced applications that, in aggregate, have the potential to change the way libraries deliver patron services. Such applications include videoconferencing, digitized content, library generated content, and centralized open source library management systems. Some of these applications exist today but are used in a basic form. With improved broadband connectivity, they can provide value in ways that may not yet have been considered.

### ***Videoconferencing***

With improvements in videoconferencing technology and the influx of BTOP funding to the library field, many library systems are expanding their use of video conferencing. Historically, library-based video services have been limited based on concerns about cost, performance, space and privacy. The most common current uses are internal staff meetings and training and limited distance learning.<sup>23</sup> However, as libraries install more sophisticated conferencing equipment and middle and last mile circuits are upgraded, an array of uses are possible. Potential uses for videoconferencing at libraries include:

- Working with elementary and K-12 schools to offer curriculum enrichment; supplemental education; virtual book chats; and virtual field trips to other parts of the country or even the world;
- Working with state agencies to enable job skills training and job interviews via videoconferencing; and,
- Working with community partners such as health organizations to offer telehealth and telemedicine capabilities from the library premises to those with hearing disabilities or those needing counseling from specialists.

Particularly in rural communities, library-based video conferencing services meet broad-based community needs. In Alaska for example video conferencing from libraries across the state, will be used to provide training and support to remote firefighters. Libraries that have thus far been unable to implement videoconferencing may benefit from speaking to their R&E networks and other service providers to understand what they offer and how they can facilitate cost effective videoconferencing.

In Oklahoma, for example, OneNet (the R&E network) plans to host, manage and administer centralized videoconferencing equipment including the bridge, call management systems and session recorders/servers. These assets, along with high-quality network connectivity from OneNet will enable dozens of public libraries to experience seamless high-quality videoconferencing with minimal equipment expense and centralized technical support.

<sup>22</sup> However, only certain VAS are E-rate eligible so service providers should consider packaging their services to maximize E-rate eligibility.

<sup>23</sup> Tight library and state budgets that limit travel also foster videoconferencing adoption. Videoconferencing is an important, and increasingly effective, substitute for travel.

### ***Digitized Content***

Although there is significant interest among library leadership, including many library directors and boards, in digitizing content for broader availability and easier consumption, implementation has been limited.<sup>24</sup> Library efforts to digitize content have focused on digitizing books for online retrieval and consumption, digitizing video content, and making already digitized materials more widely available to patrons across states. Although it has been a source of controversy, some libraries feel that digitization of non-copyrighted material can ease content sharing across libraries thereby increasing the breadth of content available to patrons. State libraries report they are placing first priority on digitizing and sharing content to which they already have the rights.

Today the sharing and consumption of content is often limited by available bandwidth. Increased bandwidth may provide an impetus to digitize and compile audio, video, and book content. In most cases, R&E networks provide unmetered intranet access to content they host or that resides on servers of other connected anchor institutions. Improved user experience through greater bandwidth on high-performance intranets may increase user demand for digitized content. Other key obstacles to leveraging digitized content are: digital rights and digital rights management challenges, lack of resources for digitization efforts, and technical challenges stemming from the diversity of library systems. R&E networks' role in enabling these efforts varies by state so libraries that wish to pursue initiatives in this space should reach out to their R&E networks to determine how they can collaborate. Collectively, R&E networks are in a position to help with technical expertise, advanced networking, hosting of content, and vendor evaluation. Many R&E networks also provide access to national and international content through connections with neighboring R&E networks and membership in Internet2<sup>25</sup>.

### ***Library Generated Content***

Another form of digitized content that R&E networks and library leaders are beginning to focus on is the content that branches themselves can generate. Libraries often serve as central venues for cultural events such as dance performances, local art shows, oral histories, and author readings. However, if the experience is limited to those that can be physically present at the time of the live performance then the audience and impact is limited. By capturing the programming through digital video and photography it can be made available to libraries throughout the community and state—or even more broadly, throughout the country, or the world. R&E networks can play critical roles in helping libraries develop these capabilities, hosting content servers, providing the bandwidth required, etc.

### ***Library Management Systems***

Library management systems (which handle the full spectrum of library day-to-day operations including but not limited to acquisition, checkout, fines, and interlibrary lending) are today typically purchased from commercial solution providers. Even open source solutions are generally operated at the local county or system level with a high level of customization that is typically done by specialized, for profit, systems integrators. Such customization, while sometimes useful, often adds complexity and fragmentation.

By enabling a centralized, state-level, cloud-based library management system, high-performance state R&E networks and hosting services could lower costs and improve services for libraries. This could improve service quality and streamline operations by enabling better coordination, service centralization, and remote management of hosted instances of individual branch systems.<sup>26</sup>

## **2b) Community**

When talking about R&E networks, both the libraries and the network leaders describe R&E networks in similar ways: “trusted advisor,” “glue that holds [the] members together,” “sharing,” and “community.” James Werle of Internet2 said,

<sup>24</sup> Access to locally produced digitized content remained flat at 43.6% from 2008 to 2009. Source: Public Library Data Service 2009 Report. Chicago, Public Library Association, 2009 as cited on page 21 of the American Library Association's “The State of America's Libraries,” April 2010.

<sup>25</sup> Internet2 provides access to programs and content across states as well as access to global research and educational content through connections with international R&E networks

<sup>26</sup> It may also make sense eventually to replace individual state's open source LMS development efforts with a national effort that eliminates duplication of effort. In doing so, it would be important to ensure that the shared system included extensive configuration/customization options to accommodate local operating differences.

“Equally or more important than the technical network is the network of people who use this network. They have to be able to share ideas and visions to understand what’s possible with these networks.”

Today there is often a knowledge and resource gap between R&E networks, which offer advanced services and are accustomed to working with members who have the technical skills and staff to use them, and libraries, which may be unaware of the various applications the networks provide. For example some libraries lack the IT support to set-up and operate a video-conferencing end-point and to remain up-to-date on the evolving variety of live, interactive video programming that is available from a global network of content providers. In part to address this gap, many R&E networks facilitate and encourage the formation and interaction of strong user communities. By bringing users with similar interests and issues together, an R&E network enables users to help each other with tactical issues such as how to use the R&E network’s services, operate a local area network, troubleshoot a router, and apply for E-Rate.

In addition to the exchange of best practices among users, there is also an information flow that occurs between network leaders and users. This two-way exchange of information and ideas provides users visibility into the finances and operations of R&E networks and gives network leaders direct feedback from the users of the network. As a result, R&E networks tend to have a democratic governance process where input from users helps network leaders manage the R&E network in a way that makes it most useful to its members.

The communities also drive beneficial “network effects” between anchor institutions and their users who both generate and consume content. A network effect is the effect that one user of a good or service has on the value of that product to other people. For Internet-based services and applications, network effects increase as more people and institutions utilize the network. For example, a library branch may purchase videoconferencing equipment, but without a network of users, instructors, and others with whom to communicate, the videoconferencing may not be utilized to its fullest potential. In this respect, R&E networks provide access to a broader community of people with educational interests. By tapping into this larger community, R&E network users are able to learn from a host of educational programs and materials from around the state, country or world that otherwise would be inaccessible.

### **More than Bandwidth: Value Added Services Make a Difference in Missouri**

**The Missouri Research and Education Network (MOREnet)** is part of the University of Missouri and is a good example of the type of organization and network that provides a broad set of value-added services to community anchor institution. In addition to providing high-speed Internet connectivity at affordable rates, MOREnet provides its members (including schools, libraries, public safety, healthcare, etc.) access to Internet2, technical support, videoconferencing services, training, and a community. In exchange, members pay annual fees for network connectivity (to cover network expenses) and a membership fee (to cover VAS and community related costs).

In addition to the premium, uncontended, Internet service, there is tremendous value in the “one-stop-shopping” that MOREnet provides. Without MOREnet’s bundled offering, community anchor institutions would have to find, select, and manage seven or more individual vendors – the effort required and expense to assemble and acquire a similar bundle of services exceeds the limited IT and management capabilities of most community anchor institutions, particularly those of most libraries.

#### **Videoconferencing**

In addition to providing a secure, reliable IP-based network for point-to-point and multipoint videoconferencing activities, MOREnet Video Services provides its members support with scheduling, room design, troubleshooting, product support and evaluations of hardware and software. Commercial alternatives to enable add-on services require purchasing media bridges, blades, port licenses, content servers, training, and device and service support. These components are often too expensive and too complicated to set-up for the community anchor institution. As a result, institutions may either be discouraged from attempting

videoconferencing or they may purchase only the endpoint equipment and have a poor experience due to missing functionality and support. By providing the centralized solution elements and support, MOREnet greatly simplifies videoconferencing for its members. Once members have purchased the necessary endpoint equipment, MOREnet takes care of the rest and ensures a high-quality user experience.

### **E-Rate Assistance**

MOREnet provides a number of classroom-style live and recorded online training sessions to members. These trainings are held year round, available to all members at no additional charge, and explain the intricacies of the E-Rate application process. The commercial alternative for such a service would require hiring an external consultant. Library staff and budgets are already stretched and the E-Rate process is complex. With services such as videoconferencing included in the application, the E-Rate process may be even more complicated. R&E networks are able to centralize the expertise to understand and drive the E-Rate process and leverage that expertise across many institutions.

### **Online Resources**

K-20 and libraries benefit from MOREnet's aggregation of database purchasing and management.<sup>27</sup> All institutional connectors can access the databases to which MOREnet subscribes (including Gale Cengage, LearningExpress Library, and NewsBank). Such resources greatly expand the value of anchor institution broadband and computing resources.

### **Consulting and Technical Support**

MOREnet, like many other R&E networks, offers free support and consultation services such as vendor evaluation, network design, analysis, and troubleshooting. They also provide router installation and management; network security and incident response services. The services are extremely valuable to MOREnet members especially if they do not have an in-house IT specialist. Hiring an internal IT manager or an external IT consultant to provide ongoing support would be prohibitively expensive.

### **Community**

MOREnet brings together like-minded institutions. When a new member joins the community, there are already hundreds of users and dozens of institutions that are part of the network. Such a community enables expertise sharing through in-person and web seminars, user forms, and sharing of technical articles relevant to the community. The involvement of a variety of institutions with different backgrounds and expertise provides useful opportunities for cooperation and cross-pollination between members. There is no commercial alternative to these communities which – by enabling institutions to share ideas, solutions, pool resources, and plan together – help transform the way that they serve the community and can enrich their users' experience.

---

<sup>27</sup> Databases are online collections of educational, career, health, and other information.

---

# Requirements for R&E Network Service to Libraries

---

There are several key factors that enable R&E networks to bring value to libraries.

The foremost of these factors is having the mission to serve community anchor institutions. Most R&E networks are *able* to serve libraries, meaning there is no statutory limitation on serving them. However, R&E networks' governing bodies (driven by founding members, often from higher education) may be hesitant to expand service due to their perception that serving libraries will dilute their focus on research.

In fact, this type of response to adding a new class of members has been a common theme over the course of the evolution and history of R&E networks. Jim Dolgonas of the California R&E network, CENIC, said, "When we started looking at serving K-12, we heard that it will drag down the support you provide to research universities, and it was the same story when we brought on community colleges." Today, K-12 and community colleges not only happily coexist with research universities, but are welcome additions to the community. Libraries, at their core, are extensions of the educational process, so serving them is highly aligned with most R&E networks' core educational missions. Expanding an R&E network's community of users increases the value of belonging to the R&E network through "network effects," that is the value to the larger network or community gained by expanding the network or community of participants. Moreover, as pointed out by Joe Freddoso of the North Carolina R&E network, MCNC, and echoed by several other R&E network leaders, adding more endpoints to the network provides a broader, more stable source of revenue and lowers the cost of membership for all, as fixed operating costs are spread across more connectors. In sum, having the ability and desire to serve libraries has real and measurable benefits to R&E networks and their existing members.

The mission and authority to serve libraries is necessary but by itself does not ensure good services for libraries. When there is an organizing and coordinating body present that brings together individual libraries to coordinate library demand and act as the intermediary between the R&E network and the public library community, that coordinating body can serve as a major facilitator in providing service to libraries. For example, Michigan's research and education network, Merit, has a mission to connect all educational institutions, including libraries; however, the libraries throughout the state are highly decentralized. It can be difficult to serve a small library in a remote part of the state that may not have a technical support staff to work with and understand the benefits of an R&E network. To counter this issue, many libraries in Michigan have formed co-operatives that can include hundreds of library branches, and Merit finds it much easier to work with these co-ops. R&E networks in California and North Carolina (CENIC and MCNC) have pointed to the community college system as an example that libraries can follow. These R&E networks successfully serve community colleges in the state, because community colleges "operate together" and "speak with one voice" through a central organizing entity. For libraries, a potential organizing and coordinating entity may be the state library agency, which already has relationships with all library branches throughout the state.<sup>28</sup>

R&E networks that systematically reach out to libraries to build awareness of their capabilities are typically able to drive greater uptake of their services. Effective outreach can even provide a compelling impetus for libraries to organize and coordinate efforts. This has been successful in Missouri, where MOREnet proactively reaches out to libraries that are not currently participating in MOREnet and to current members to make sure they are aware of the host of services that are

---

<sup>28</sup> Most states have regional cooperatives of some type. But how they are funded and what their responsibilities are vary greatly. OITP has documented these variations and the benefits of regional cooperatives. See its report "Regional Library Cooperatives and the Future of Broadband" at <http://www.ala.org/ala/aboutala/offices/oitp/publications/issuebriefs/rlc.pdf>

available. As a result, 134<sup>29</sup> of the 151<sup>30</sup> public libraries in Missouri are members of MOREnet. One of the more creative ways of generating awareness and encouraging usage of services was heard from Network Nebraska. This R&E network provides videoconferencing services, which are used for distance learning throughout Nebraska. To encourage usage, the state uses lottery funds to provide schools an incentive of \$1,000 per semester course sent *or* received, plus a bonus of \$1,000 if the course reaches a sparsely populated area. Although this program is specific to K-12, it is an example of how R&E networks, libraries, and state governments can work together to promote adoption of broadband and advanced services enabled by R&E networks.

Finally, the ability of R&E networks to cost effectively serve libraries often depends critically on the reach of their middle mile infrastructure and the ability to build fiber laterals that directly connect libraries to R&E networks. Many of the recently awarded BTOP infrastructure grants are enabling R&E networks and commercial operators to work together to expand their middle mile fiber networks into previously underserved areas. In addition, some of these funds have been allocated to building last mile connections directly to libraries. These funding efforts have:

1. Increased the number of libraries that directly connect to an R&E network. Based on current commitments, 61 projects will serve a total of 2,381 public libraries.
2. Helped R&E networks expand their missions to include libraries. For example, Colorado's EAGLE-Net will connect 26 libraries.
3. Enabled partnerships among commercial and nonprofit providers to connect community anchor institution to the R&E network middle mile backbone. One case in point is the partnership between Zayo Bandwidth and I-Light to create last mile connections in Indiana.
4. Added backbone and middle mile capacity across the country that will lower cost structures for providers serving rural and remote areas of the country.

### ***Other Requisites***

While the critical factors that enable successful R&E network/library collaborations, success also hinges on the availability of technical staff resources, levels of E-Rate utilization, and last mile circuit cost levels. R&E networks cannot solve these issues alone. State library associations, library consortia, library systems, individual libraries, their communities, and others have roles to play.

#### **1. Technical resources**

Many libraries, especially smaller libraries, do not have sufficient technical staff to support installation and ongoing maintenance of networking equipment or to manage technologies that take advantage of advanced service offerings that R&E networks provide.

Libraries and R&E networks that tackle this problem from multiple angles seem to have the best rate of success. R&E networks may look to scale support capabilities (e.g., more staff and better remote management and support capabilities) and conduct formal training for library staff to better enable them to interface with R&E networks for installs, support, and troubleshooting. Some also make it a point to integrate training into their responses to support needs (teaching the library staff how to prevent or address the problem in the future). Some R&E networks are also thinking about how to simplify and package their services to make them more user-friendly (easier to deploy and manage) for less technically sophisticated community anchor institutions. This need can also be addressed in the library field where library leaders such as state library authorities provide centralized or regional staff to support technology assessments and planning.

#### **2. E-Rate utilization**

The E-Rate program is designed to make broadband connectivity more affordable for schools and libraries, but the application process and burden of applying, on staff at these institutions, are barriers that prevent some libraries from realizing the benefits of E-rate. In addition, E-Rate web content filtering requirements pose conflicts for some public librarians who may be philosophically opposed to censorship, while others find the requirement cumbersome to

<sup>29</sup> REAL Program Participants List, <http://www.more.net/content/real-program-participants>.

<sup>30</sup> *Public Libraries in the United States*, Institute of Museum and Library Services, June 2009.

implement and manage. In many states, fewer than half of all libraries utilize E-Rate, and therefore do not benefit from a potentially significant source of funding for Internet connectivity.

Recent changes to E-Rate program rules should ease restrictions and reduce the administrative burden of applying for funding. However, R&E networks and library leadership can still play a role in broadening public library participation in the E-Rate program. The degree of explicit cooperation that is permissible under the E-Rate program is somewhat open to interpretation. However, in some cases libraries and R&E networks have successfully collaborated to coordinate their E-Rate process in ways that enable R&E networks to submit consortia E-Rate applications on behalf of several public library systems. R&E networks can also help libraries by providing filtering advice and services enabling the libraries to meet program requirements.

### **3. Last mile circuit costs**

Tail circuits can be quite expensive, especially in geographically isolated areas. R&E networks that have been most successful in serving community anchor institutions and libraries have identified a number of avenues that help address circuit costs. The most direct approach involves building and operating more last mile circuits. Where that is not feasible, R&E networks often aggregate circuit purchases from commercial service providers and cultivate competitive bidding for last mile circuits by identifying and recruiting alternative providers in an area.

Some libraries and other community anchor institutions have also reduced last mile circuit costs through creative solutions such as developing hub and spoke architectures (enabling a single outside connection to feed a local area with multiple community anchor institutions) or by opportunistically piggy-backing connectivity from a nearby entity with a robust connection.<sup>31</sup>

---

<sup>31</sup> Finding these opportunities can be difficult for libraries. Some R&E networks may have the tools and expertise to provide support in this area.

---

# R&E Networks Are Well Positioned to Serve Libraries

---

We are in the midst of a period of rapid broadband service expansion in the United States. This exciting change is occurring as a result of technological innovation, market forces, the efforts of network operators of all types, and federal stimulus funding. Libraries have a range of broadband service choices available to them, from commercial and government networks to R&E networks. These networks provide widely varying and continually evolving menus of service offerings to community anchors.

At the same time that broadband connectivity is becoming more available to libraries, the needs of libraries are expanding as library users require increasing opportunity online at the library. Library leadership is actively adapting services to better meet community needs for information and collaborative learning online. As public libraries expand the range of broadband related applications and services that they use, they are becoming increasingly sophisticated buyers of network services – moving beyond simply assessing the price and speed of their provider options to considering the quality of the connection and the accompanying value-added services a provider offers.

This is a critical point in time for libraries to consider a broader range of connectivity strategies and provider types. To that end we have sought to provide insight into the key considerations libraries could explore when considering connections from R&E networks and other nonprofit networks.

R&E networks can often be a good option for libraries seeking a new Internet provider. They offer a formidable set of benefits including high-quality Internet service and for the provision of value-added services and user communities that can help libraries learn about best practices in video conferencing, cloud computing, and enriched digital services. More importantly, the association with other intensive network user help library IT staff stay abreast of “what’s next” in Internet trends and services.

However, there are challenges for libraries that want to partner with an R&E network. Libraries may be too far from their state R&E network to connect with the network efficiently, or at all; they may not be eligible for membership within the network; or they may lack the fiscal or technical resources to establish and maintain a connection with the network. R&E networks are making efforts to address these challenges, but still, R&E networks may not ultimately be the best solution for every library or anchor institution.<sup>32</sup>

Ensuring efficient, effective, and continuously improving Internet service to all public libraries and other anchor institutions will require the resources and unique capabilities of all types of public and private networks. Library leaders need to understand the variety of Internet service options available to them and should continue to choose their providers based on thoughtful consideration of library needs, resources, and anticipated changes in user demand.

---

<sup>32</sup> R&E networks and the library community are making efforts to address these challenges to help reach the goal in the National Broadband Plan that “Every American community should have affordable access to at least 1 gigabit per second broadband service to anchor institutions such as schools, hospitals and government buildings.” For example, since the Plan’s release in March 2010, Internet2 and the R&E networks have been cooperating with the American Library Association’s Office for Information Technology Policy (OITP) and state library agencies to work on ways to connect libraries to R&E networks. This is being done in the framework of the National Broadband plan recommendation 8.22 that references the Internet2 proposal to create a coordinating entity, the “Unified Community Anchor Network,” (UCAN), to help community anchor institutions in obtaining and utilizing broadband connectivity. R&E networks may not ultimately be the best solution for every library or anchor institution but the UCAN will be one important model for fostering library connectivity to R&E networks.

## Appendix: Dimensions of R&E Networks

In the preceding examination of R&E networks we alluded to their range of capabilities and limitations. In this appendix, we systematically deconstruct these models and examine the implications of these differences. Better understanding the characteristics of a specific network and organization can help anchor institutions make more informed service decisions about membership and service. This review may also help R&E network leaders consider options as they evolve.

As illustrated in *Exhibit 6*, R&E networks exhibit variations along at least seven dimensions.<sup>33</sup> In the body of this paper, we discussed scope of membership and service depth as gating indicators, but the other dimensions also shape the organization and network. These are geographic reach, origin, governance, business model and network topology.

Using this section as a reference, libraries and other community anchor institutions considering connection to an R&E network can reach out to their state R&E network and determine whether they are eligible to be connected and what options they have in terms of the services to be included. R&E networks do not always publish the full extent of available services so it is important for community anchor institution to ask questions.

### Exhibit 6: The Seven Dimensions that Define R&E Networks

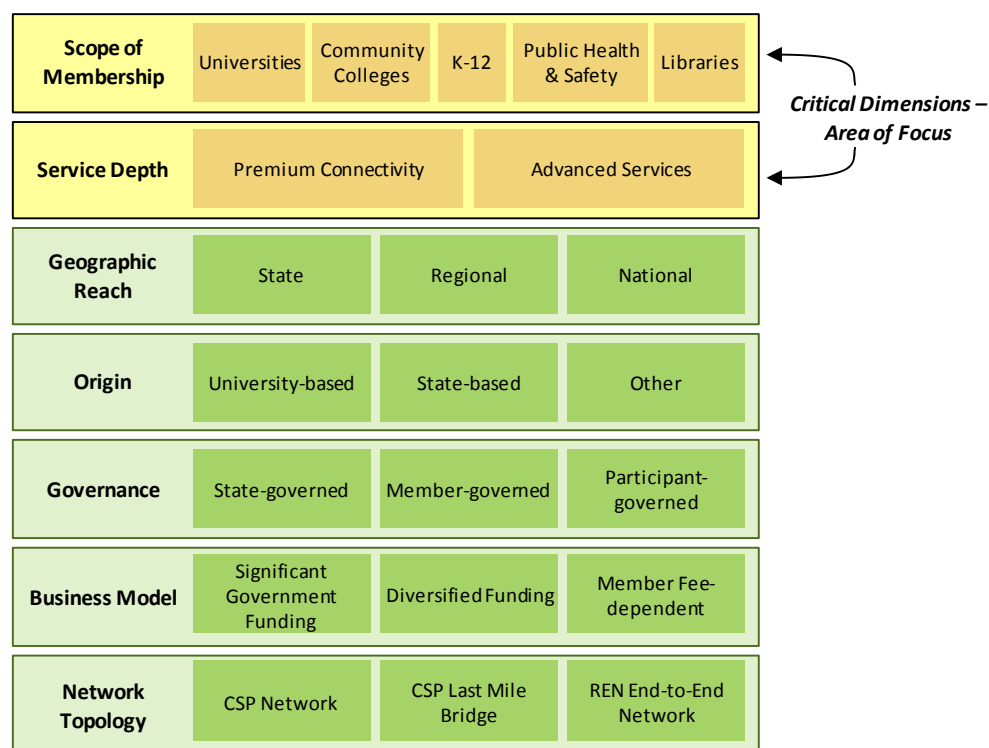

There are a host of other important networks that exhibit many of the characteristics described in this paper. Many of them do, or could, support libraries and community anchor institutions. These include state agency networks, municipal networks, networks founded through public-private partnerships, university LANs and WANs, and library system WANs. Some commercial service providers such as Education Networks of America (ENA) also offer value propositions similar to those provided by nonprofit R&E networks.

<sup>33</sup> This is but one approach to describe and classify R&E networks. These seven dimensions captured the aspects most relevant to our analysis.

## SCOPE OF MEMBERSHIP

*Types: Universities, +Community Colleges, +K-12, +Public Health & Safety, +Libraries*

As discussed in the *History and Origin of Research and Education Networks* section above, most of the early R&E networks began with a *narrow* scope of membership, serving mainly colleges and universities. Over time, many R&E networks viewed K-12 and community colleges as a logical extension of the education focus of their charter, and therefore expanded their memberships to serve all of *K-20*. Recently, there has been additional movement toward *broadening* this membership further to include community anchor institutions (including public libraries). *Exhibit 9* in this appendix, as a current snapshot of active state R&E networks and the types of community anchor institutions each serves, illustrates the scope of membership concept.

Networks that have begun to include a broader set of community anchor institution in their membership such as Merit, MOREnet, and UEN point to important benefits such as:

- Broader, more stable, and sustainable bases of revenue
- Economies of scale (adding more connectors lowers the per connector cost associated with R&E network membership)
- Increased network effects across community anchor institution to enhance and better utilize the value of R&E network community and content (adding more content creators and programming audiences)
- Creating educational opportunities beyond schools by connecting libraries

## SERVICE DEPTH

*Types: Premium Connectivity, Advanced Services*

The services offered by R&E networks vary widely, but they can be divided into two categories: those that offer advanced services in addition to premium connectivity and those that do not. *Premium connectivity* enables network connectors to rapidly transmit large amounts of data and implement applications that require low latency and high-quality of service. For connectors who just need a “fat pipe” and do not want or need extra services that may increase the cost of R&E network membership, R&E networks offering only premium connectivity may be preferable.

R&E networks may also offer *advanced services* that provide additional value to their connectors. Examples of these include videoconferencing, service centralization/cloud computing, shared online resources, E-Rate assistance, technical support, and network consulting. Offering these services may not only enhance the value proposition of an R&E network, but may also reduce participants’ overall broadband-related costs. The benefits of providing a deeper, more comprehensive set of services are detailed in the *Value Proposition* section.

## GEOGRAPHIC REACH

*Types: State, Regional, National*

For the most part, R&E networks exist in a geographic hierarchy with three levels: state, regional, and national.

For the purposes of this paper, a state R&E network is a network whose fiber assets exist predominantly within a single state and whose general objective is to connect institutions across as much of the state as possible (even if there are parts of the state not reached by the network). State R&E networks provide *intrastate* connectivity to and between institutions within a given state and connect nationally and to the Internet through national R&E networks and commercial ISPs. They also provide an array of value-added services and community related benefits. There are currently 38 active state R&E networks and three proposed new R&E networks (NH, PA, and WV).

Regional R&E networks tend to connect multiple state R&E networks or institutions across a few states in a given region. The approximately 15 regional R&E networks also help connect state R&E networks to the national R&E networks. The result is a patchwork of networks that enables institutions to connect locally, regionally, and nationally.

At the national level, the two major R&E networks are Internet2 and National LambdaRail. In *Exhibit 7*, Internet2 is represented by the black line, which spans the country and has points of interconnection with several regional and state networks. Historically, the main purpose of national R&E networks has been to operate high-speed, high-performance IP

backbones that provide *interstate* connectivity between institutions across the country. They also directly connect many major government and university research facilities and connect with major international research and education networks.

Today Internet2 provides value by offering high-performance videoconference bridging services, shared programs and content (e.g., courses for K-20), a national user community, testing, advanced technical capabilities and national advocacy. Internet2 also provides connectivity to global R&E networks, as well as a global community of users and global research and educational content.

### Exhibit 7: A Map Illustrating the Relative Reach of Select Regional and National R&E Networks

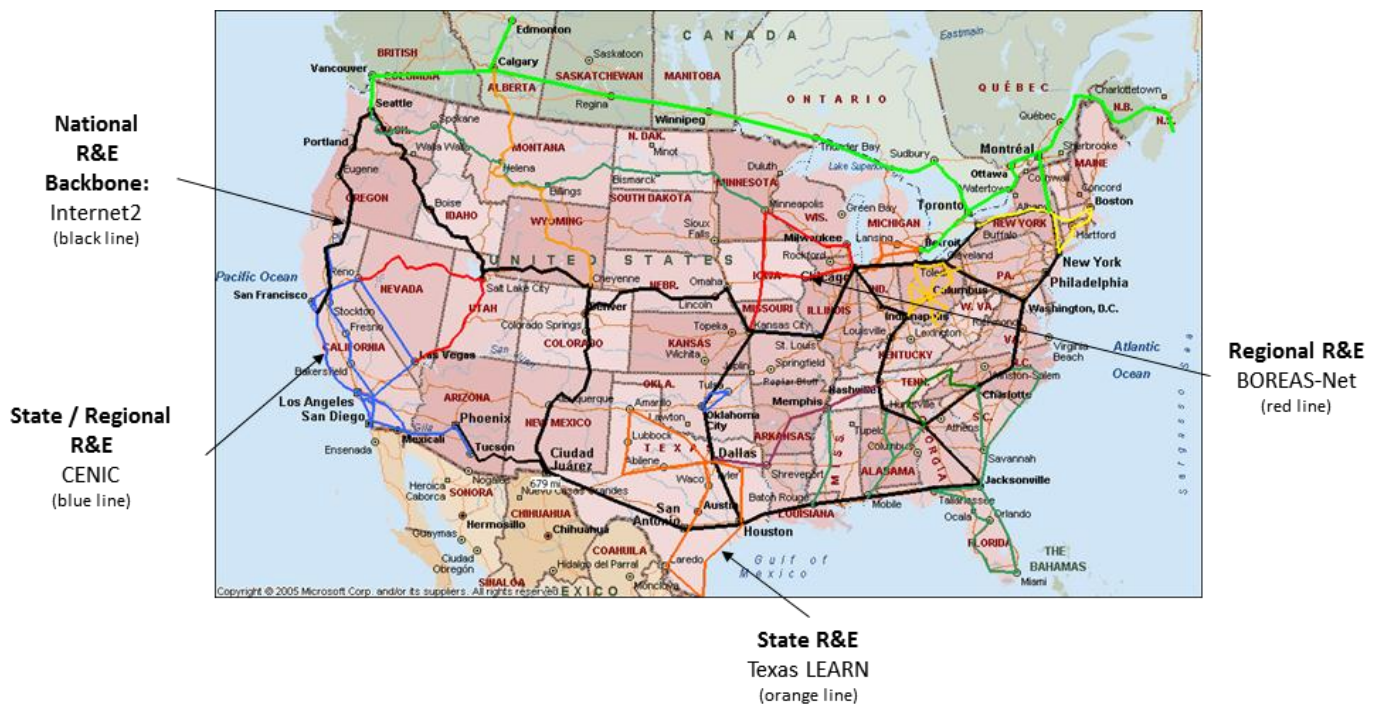

## ORIGIN

*Types: University-based, State-based, Other*

Most R&E networks' beginnings are rooted in a university (or group of universities) or state government. State universities are often major drivers so the distinction between a university origin and a state origin is subtle. University-originated R&E networks were typically founded through consortia of universities to connect researchers as a means of expanding and supporting research collaboration. State-originated R&E networks were typically created by a legislative statute or through a committee created by the state government. A few networks, which we classify as "Other" origin, were formed by a combined effort of research universities, state government, and/or corporations (e.g. NYSERNet).

The line has blurred as some R&E networks originally formed by universities have taken on greater state involvement, but understanding an R&E network's roots is important, because why and how an R&E network was formed shapes its mission and objectives.

## GOVERNANCE

*Types: State-Governed, Member-Governed, Participant-Governed*

R&E network governance models exist on a spectrum of representation. On one end is the model where the *state* governs the R&E network, which is most likely in R&E networks that have a state-based origin. *Member* and *participant* governance are characterized by more direct representation of connectors.<sup>34</sup> A “member” is typically one of the few founding entities or major institutions that belong to an R&E network., A “participant” pays dues/fees (where applicable), and uses the R&E network’s services, but tends to be a smaller entity.

The *participant-governed* model is most representative, as each constituent group (e.g. universities, K-12 school districts, public libraries, and community colleges) has voting representatives that help guide the R&E network.

## BUSINESS MODEL

*Types: Significant Government Funding, Diversified Funding, Member Fee-Dependent*

R&E networks sustain operations using three main variants of business models, which range from a reliance on government (usually state) funding to reliance on fees paid by members. It is important to note that these business models represent the primary source(s) of funding operations and that funding sources often overlap. For example, R&E networks using the *government funding* model fund a *significant* portion of their operating budgets through state and/or federal appropriations, but also collect member fees. Likewise, an R&E network whose continuing operating expenses are mostly funded by network connection fees and/or membership dues paid by members and affiliates may also receive minimal or occasional state or federal funding. A *diversified funding* model is one where funding contributions by government and member fees are relatively balanced.

Though there is not necessarily an optimal business model, there is evidence that over-reliance on state funding can lead to disruption if the state funding is cut in an economic downturn. Consequently, moving towards a membership fee model may have favorable ramifications for operational stability and sustainability. Most R&E networks have also made effective use of grants as an occasional source of project-specific funding. Grants can improve an R&E network’s sustainability by enabling it to add connectors and scale without incurring the full capital expense of extending its reach.

## NETWORK TOPOLOGY

*Types: CSP Network, CSP Last Mile Bridge, End-to-End R&E Network*

The three main types of network topologies are 1) a Commercial Service Provider (CSP) operates all network segments, 2) the R&E network has middle mile network assets, but relies on the CSP to bridge the last mile, and 3) the R&E network runs an end-to-end network. In the third topology, where the R&E network operates the end-to-end network, the provider has the greatest control of price and service quality. This sometimes confers cost savings via ownership economics to the R&E network and its members.

### Exhibit 8: The Various Types of R&E Network Topologies<sup>35</sup>

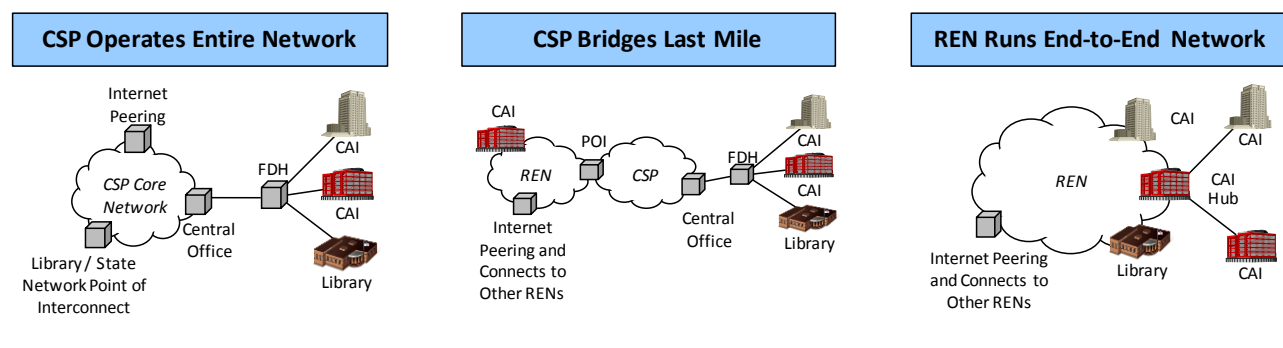

<sup>34</sup> Note that there is no standardization of the terms member and participant across R&E networks so it is important for community anchor institutions to make sure that they understand the role and rights of various levels of members within their state R&E network.

<sup>35</sup> Key to Exhibit 8 Acronyms: CSP=Commercial Service Provider, REN=Research and Education Network, FDH=Fiber Distribution Hub, CAI=Community Anchor Institution, POI=Point of Interconnect

### Exhibit 9: Active State R&E Networks and Community Anchor Institutions Currently Served<sup>36</sup>

Note that this table is based on R&E network web sites, other public sources, as well as interviews with R&E network leaders and other sector experts. While we believe the data to be complete and accurate, it can only reflect our view of the current status in this very dynamic environment. Community anchor institutions should consult with their respective state R&E networks to determine whether they are eligible for service.

State	R&E Network	Universities	Community Colleges	K-12	Libraries	Healthcare	Government / Public Safety
Alabama	Alabama REN	•	•	•	•	•	•
Alaska	AK20	•		•	•		
Arkansas	ARE-ON	•					
California	CENIC / CalREN	•	•	•			
Colorado	EAGLE-Net / Front Range GigaPOP	•	•	•	•	•	•
Connecticut	CT Education Network	•	•	•	•		•
Florida	Florida LambdaRail	•	•				
Georgia	PeachNet	•		•	•		
Hawaii	HERN	•	•	•	•		
Idaho	ID Education Network			•			
Illinois	ICN	•	•	•	•	•	•
Indiana	I-Light	•					
Iowa	ICN	•	•	•	•	•	•
Kansas	KanREN	•	•	•	•		
Kentucky	KyRON	•	•	•	•		
Louisiana	LONI	•	•				
Maine	MaineREN	•		•	•		•
Michigan	Merit Network	•	•	•	•	•	•
Minnesota	Learning Network of MN	•	•	•	•		•
Missouri	MORENet	•	•	•	•		•
Nebraska	Network Nebraska	•	•	•			
Nevada	NevadaNet	•	•	•			•
New Jersey	NJEDge	•	•			•	
New Mexico	CHECSNet	•	•	•			
New York	NYSERNet	•		•	•	•	
North Carolina	MCNC / NCREN	•	•	•	•	•	•
North Dakota	STAGENet	•		•			•
Ohio	OARNet	•	•	•		•	
Oklahoma	OneNet	•	•	•	•	•	•
Oregon	NERO / Oregon GigaPOP	•		•	•		•
Rhode Island	OSHEAN	•		•	•	•	•
South Carolina	South Carolina LightRail	•					
South Dakota	REED	•					•
Texas	LEARN	•	•	•			
Utah	UEN	•		•	•		
Virginia	NetworkVirginia	•	•	•	•	•	•
Washington	K20 Education Network	•	•	•	•		
Wisconsin	WiscNet	•	•	•	•	•	•

<sup>36</sup> Note that other networks exist in each of these states that also serve anchor institutions. MassBroadband 123 in western Massachusetts, Vermont FiberConnect, and ENA (in Tennessee and Indiana) are examples of significant networks planning to connect or already connecting libraries which are not included in Exhibit 9.